



## WISE-7902/WISE-7902D

FRnet Remote I/O PoE Module

### FRnet Remote I/O Modules

#### Features

- Built-in Web Server for IF-THEN-ELSE rule setting
- Built-in IF-THEN-ELSE rule engine for logic operation
- No more programming. Just click and get done!
- Support IO, Counter, Timer, Email operations
- Modbus/TCP Protocol for SCADA Software Seamless Integration
- IEEE 802.3af-compliant Power over Ethernet (PoE)
- 10/100 Base-TX Ethernet
- Support FRnet Modules: FR-2053T, FR-2054T, FR-2057T



#### Introduction

WISE (Web Inside, Smart Engine) is a product series developed by ICP DAS that functions as control units for use in remote logic control and monitoring in various industrial applications. WISE offers a user-friendly and intuitive web site interface that allows users to implement IF-THEN-ELSE control logic on controllers just a few clicks away; no programming is required. With its powerful and easy-to-use features, it will minimize the learning curve, shorten time to market and dramatically reduce the effort and cost spent on system development.

WISE-7902 follows IEEE 802.3af-compliant (classification, Class 1) Power over Ethernet (PoE) specification. It allows receiving power from PoE enabled network by Ethernet pairs (Category 5 Ethernet cable). This feature provides greater flexibility and higher efficiency therefore simplifying systems design, saving space, reducing cables and eliminating the requirement for dedicated electrical outlets. Meanwhile, in case under a non-PoE environment, WISE-7902 will still be able to receive power from auxiliary power sources like AC adapters or battery, etc.

This module WISE-7902 supports Modbus/TCP protocol to make seamless integration with SCADA software available. It supports an I/O expansion bus to implement various I/O functions such as D/I and D/O according to the using FRnet modules: FR-2053T, FR-2054T, and FR-2057T.

#### Applications

Building Automation, Factory Automation, Machine Automation, Remote Maintenance, Remote diagnosis and Testing Equipment, etc.

#### Specifications

Models	WISE-7902	WISE-7902D
<b>CPU Module</b>		
CPU	16-bit CPU	
SRAM	512 KB	
Flash	512 KB	
EEPROM	16 KB	
NVRAM	31 Bytes	
OS	MiniOS7	
RTC (Real Time Clock)	RTC Provide seconds, minutes, hours, date of week/month; month and year, valid from 1980 to 2079	
64-bit Hardware Serial Number	Yes	
Watchdog Timers	Yes (0.8 second)	
<b>Communication Ports</b>		
Ethernet	RJ-45 x 1, 10/100 Base-TX (Auto-negotiating, Auto MDI/MDI-X, LED indicators)	
COM 1	No (Unsupported by WISE firmware)	
COM 2	No (Unsupported by WISE firmware)	
FRnet	Max. 1 M	
<b>LED Indicator</b>		
System LED	Yes (Red)	
LED Display	-	5-digit 7-segment LED display
Special Indicator	PoE LED (Green)	
<b>Mechanical</b>		
Dimensions (W x H x D)	72 mm x 123 mm x 35 mm	
Installation	DIN-Rail or Wall Mounting	
<b>Environmental</b>		
Operating Temperature	-25 ~ +75 °C	
Storage Temperature	-40 ~ +80 °C	
Ambient Relative Humidity	5 ~ 90% RH (non-condensing)	
<b>Power</b>		
Protection	Power reverse polarity protection	
Frame Ground	Yes (for ESD Protection)	
Input Range	+12 ~ +48 V <sub>DC</sub>	
Power over Ethernet (PoE)	IEEE 802.3af Class 1	
Power Consumption	1.5 W	2.5 W

## Software Specifications

Functions	
Rule Configuration Website	Access Web server on WISE controllers to edit and upload logic rules through web browser.
36 IF-THEN-ELSE Logic Rules	3 IF conditions with AND or OR operators 3 THEN actions and 3 ELSE actions
48 Internal Registers	Hold temporary variables and read/write data via Modbus/TCP address.
12 Timers	Delay / Timing functions.
12 Schedules	Setup prescheduled routine tasks.
12 Emails	Send Email messages to pre-set Email receivers.
12 CGI Commands	Send pre-set CGI commands.
12 Recipes	Set up THEN/ELSE action groups.
8 P2P remote modules	Set up the connection information for the remote WISE modules.
Modbus/TCP Protocol	Real time control and monitoring I/O channels and system status of controllers via SCADA software.

IF Conditions	
DI Channel	ON - OFF - ON to OFF - OFF to ON - Change
Internal Register	= > < >= <=(value) · Change
DI Counter	= > < >= <=(value) · Change
DO Counter	= > < >= <=(value) · Change
Timer	Timeout - Not Timeout
Schedule	In Range - Out of Range
P2P	DI - AI - DI counter - DO counter - IR
Rule Status	Enable - Disable

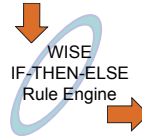

THEN / ELSE Actions	
DO Channel	ON - OFF - Pulse Output
Internal Register	Change the value
DI Counter	Reset
DO Counter	Reset
Timer	Start - Stop
Schedule	Start - Stop
Email	Send
CGI Commands	Execute
Recipe	Execute
P2P	DO(On/Off) - AO - IR
Rule Status	Enable - Disable

## Pin Assignment

Terminal No.	Pin Assignment
E1	Link/Act 10/100M
COM1	01 CTS1 02 RTS1 03 Rx/D1 04 Tx/D1 05 INIT*
COM2	06 D2+ 07 D2- 08 (R) +Vs 09 (B)GND

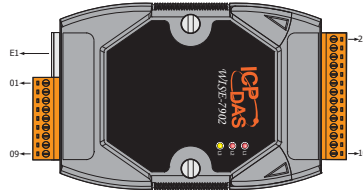

Terminal No.	Pin Assignment
23	-
22	-
21	-
20	-
19	-
18	-
17	FRnet Port A
16	FRnet Port A
15	FRnet Port B
14	FRnet Port B
13	-
12	-
11	-
10	-

## Wiring

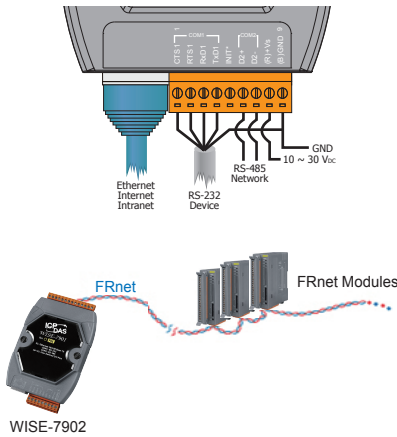

## Dimensions (Unit: mm)

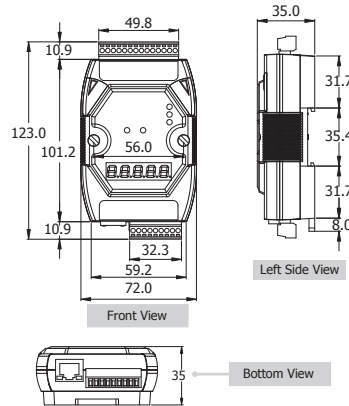

## Ordering Information

WISE-7902	FRnet Remote I/O PoE Module
WISE-7902D	FRnet Remote I/O PoE Module with LED Display

## Accessories

GPSU06U-6	24V/0.25A, 6 W Power Supply
MDR-20-24	24V/1A, 24 W Power Supply with DIN-Rail Mounting
NS-205 CR	Unmanaged 5-Port Industrial Ethernet Switch (RoHS)
NS-205PSE CR	Unmanaged 5-Port Industrial PoE Ethernet Switch (RoHS)
FR-2053T	16-channel Isolated Sink Digital Input Distributed I/O Module
FR-2054T	8-Channel Digital Output and 8-Channel Digital Input Module
FR-2057T	16-Channel Isolated Sink Digital Output Distributed I/O Module