

# RHINO DC to DC Converters

Four models for DC input voltage are available in the PSP series of DIN-rail DC-to-DC converters. Wide input ranges of 9.5 to 18VDC and 18 to 75VDC allow these models to be operated from all popular DC supply voltage systems. With tightly regulated output voltage these DC/DC converters provide a reliable power source for sensitive loads in industrial process controls, factory automation and other equipment exposed to a critical industrial environment. They can be used to isolate a specific load from the 24 volt bus voltage, and offer easy installation with snap-on mounting on DIN rails and detachable screw terminal block.

## Features

- Ultra-wide input voltage range
- Output voltage adjustable
- Overload and short circuit protection
- Low ripple and noise
- I/O-isolation 1500 VDC
- Compact, slim plastic case
- Reliable snap-on mount on 35mm DIN rail
- Wall-mount bracket included
- 3-year warranty



PSP12-DC24-2



PSP24-DC12-1



PSP05-DC24-5



PSP24-DC24-1

Input Specifications					
Part Number	Input Voltage Range	Input Power (no load)	Startup Voltage	Undervoltage Shut-down	Efficiency (Typical)
PSP24-DC12-1	9.5 – 18.0 VDC	1.0 W. max	8.4 VDC	7.6 VDC	86%
PSP05-DC24-5	18 – 75 VDC		17.2 VDC	15.7 VDC	
PSP12-DC24-2					
PSP24-DC24-1					

Output Specifications									
Part Number	Price	Output Voltage	Output Voltage Adj. Range	Output Current (Max.)	Ripple/Noise	Output Voltage Regulation*	Overvoltage Protection, Trigger Point	Short Circuit Protection	MTBF (IEC 1709 @ 25°C)
PSP24-DC12-1	<-->	24 VDC	24.0 - 28.0 VDC	1 A	<50mV peak to peak	±0.5 % max	<42 V	Current limited at 110% typical	2.5 million hours
PSP05-DC24-5	<-->	5 VDC	5.0 - 5.25 VDC	5 A			<6.5 V		
PSP12-DC24-2	<-->	12 VDC	12.0 - 15.0 VDC	2 A			<24 V		
PSP24-DC24-1	<-->	24 VDC	24.0 - 28.0 VDC	1 A			<42 V		

\*Note: Input variation  $V_{in\ min}$  to  $V_{in\ max}$  and load variation 0 to 100%

# RHINO DC to DC Converters

General Specifications	
<b>Temperature: Operating</b>	-10°C to 70°C max (14°F to 158°F max)
<b>Storage (non-operating)</b>	-25°C to 85°C max, (-13°F to 185°F max)
<b>Derating</b>	1.5%/K above 50°C (122°F)
<b>Humidity (Non-condensing)</b>	95 % relative humidity max.
<b>Temperature Coefficient</b>	0.02 %/K
<b>Switching Frequency</b>	55 – 180 kHz depending on load (frequency modulation)
<b>Isolation Voltage (1 min.) – Input/Output</b>	1500 VDC
<b>Reliability, Calculated MTBF @ 25°C</b>	>2.5 Mio h (according to IEC-1709)
<b>Safety Standards</b>	IEC 60950-1, EN 60950-1 (output SELV), UL/cUL 60950-1, EN 60204
<b>Electromagnetic Compatibility (EMC), Emissions</b>	EN 61000-6-3
<b>Electromagnetic Compatibility (EMC), Immunity</b>	EN 61000-6-2
<b>Safety Class</b>	Degree of protection class 1
<b>Enclosure Rating</b>	IP 20 (IEC 60529)
<b>Enclosure Material</b>	Plastic FR2010-110C (UL 94V-0 rated)
<b>Mounting</b>	DIN rails per EN 50022-35x15/7.5 (snap-on with self-locking spring) bracket for wall/chassis mount included
<b>Agency Approvals UL Approval CB Report</b>	UL/cUL 508 Listed, File E197592, CE
<i>Note: All specifications valid at nominal input voltage, full load and +25°C after warm-up time unless otherwise stated.</i>	

## Dimensions

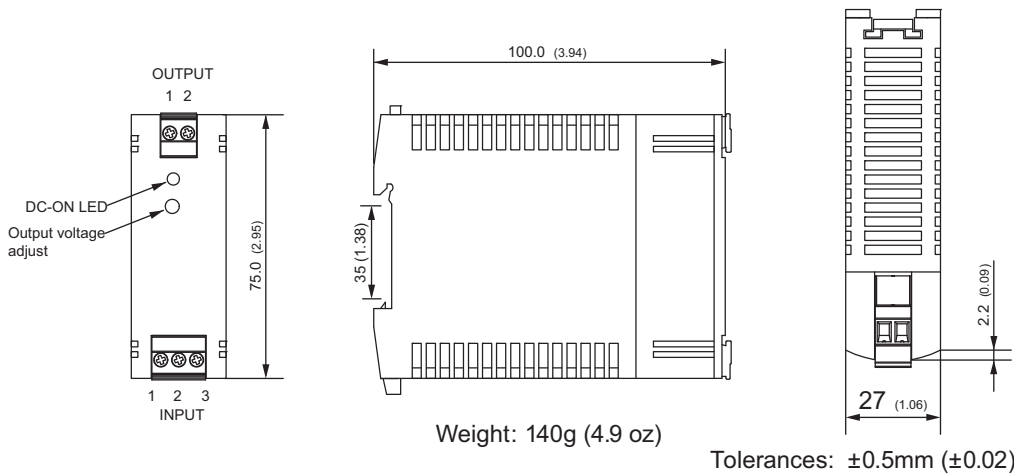

Input	Output
1 Ground	1 +Vout
2 -Vin	2 -Vout
3 +Vin	

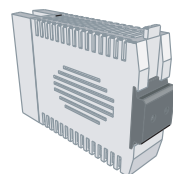

The unit can be mounted on a chassis or wall using the included mounting bracket.